

Solar Laundry Trailer

A proposal for Dignity Village

INTRODUCTION:

Dignity Village (on 33rd), as well as other shelters, need laundry and communications facilities, but lack power and water. This proposal describes a Solar charged battery-power laundry facility for Dignity Village, and provides internet communications for Village residents.



DESCRIPTION:

A single axle, 6x12 foot trailer (\$2000) supports a fully built \$20K A-frame, Both 8x12 ft sides of the A-frame support 1200 watts of solar (4x350 watts) for \$2400. The panels feed two Bluetti ep500 (\$6000) which features 5100Wh of LiFePO4 battery storage, 2000W pure sine wave output, and features 220 volt output. Two 50 gallon drums provide water intake and waste storage.



PORTLAND
CLEAN ENERGY
INITIATIVE

This proposal is intended to utilize Portland Clean Energy Funding and will ask for approximately \$75K. It would utilize the skills of minority youth to construct and assemble the unit, while funds will be allotted to provide responsible parties at homeless communities to manage and transport the unit.

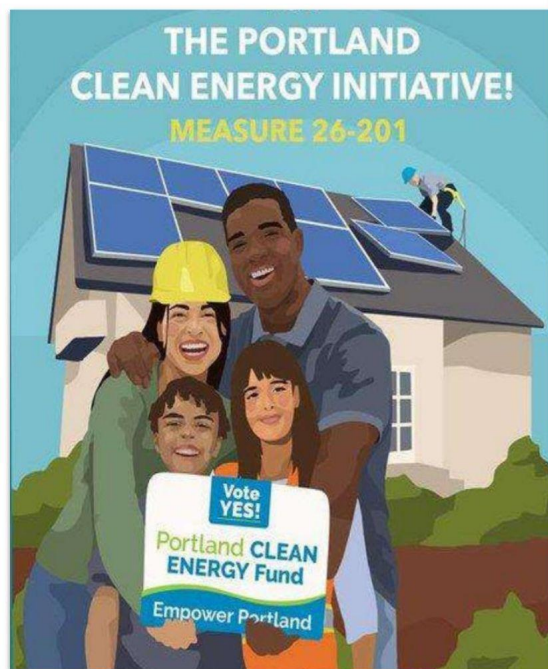

WHO: *Portland Clean Energy Fund* is a ballot initiative that was passed in 2018. It funds green energy programs that will benefit low-income residents and communities of color.

WHAT: The *Clean Energy Fund* collects some \$40-\$60m annually, raised by a 1% business tax on largest 1% (retail with over \$1 billion annual revenue). Food, utilities & small business <\$500K in Portland not taxed.

WHERE: Grants will install solar, weatherize homes, provide job training & expand local food production.

WHEN: The FIRST grant proposals will be announced Feb 2021, totaling \$8.6 million.

WHY: Black, Indigenous, and people of color are most impacted by climate change but have been excluded from the emerging low-carbon economy

<https://portlandcleanenergyfund.org>

The Portland Clean Energy Fund taxes large retailers. That revenue will amount to \$40-60 million each year. All of it is reserved for communities of color and those with low income who are more likely to suffer from the effects of climate change.

Distribution of the PCEI

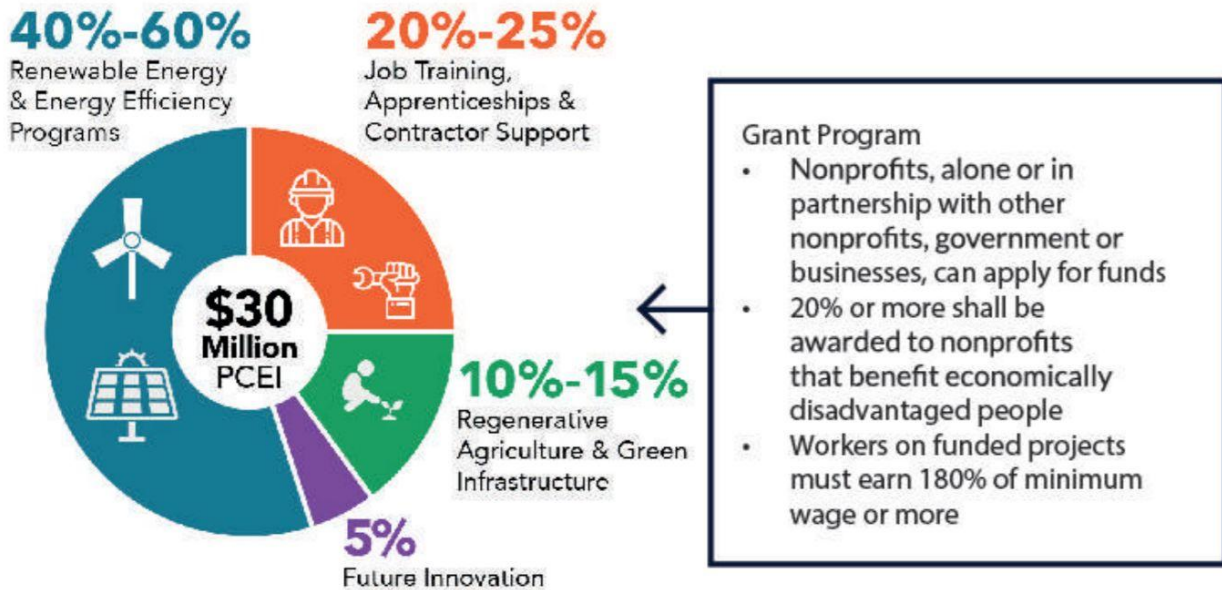

At least 50% of grant-funded energy efficiency/renewable energy projects will “specifically benefit low-income residents and communities of color;” and at least 20% of all grants “shall be awarded to nonprofit organizations with a mission and track record of programs that benefit economically disadvantaged community members.”

COMPONENTS:

1. [The Bivvi Cabin](https://bivvicamp) is an A-frame cabin made in Portland that can easily be transported on a trailer. It features sealed tongue-and-groove cedar siding, full insulation, a large picture window, a door porthole window, and long-lasting metal roofing. The \$20K Bivvi arrives fully built, eliminating costly on-site construction costs and measures 8'6" wide by 11'6" long and 10'6" tall—which allows it to be legally transported on roads. <https://bivvicamp>.



- Solar Panels.** The 8 X 10 foot "roof" can hold 1200 watts of solar on each side of the "A" frame. Four Renogy 320 Watt, 24 Volt black frame Monocrystalline Solar Panels cost \$325 each (four for \$1300). Two 1200 watt solar arrays would be \$2600. Dimensions are 66" by 40" by 1.4 in. Four solar panels would measure 132" by 80" (11 ft by 6.6 ft), which fits on the 11 ft by 8.5 ft side.

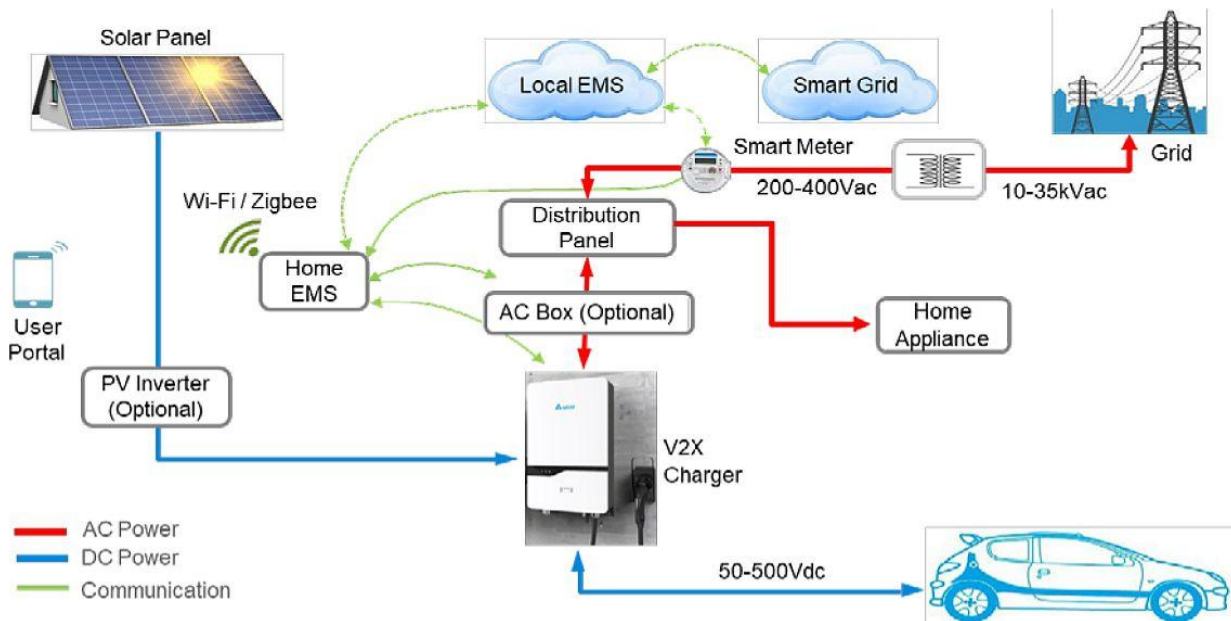

3. Battery Pack.

The Bluetti ep500 (\$2700) home battery features 5100Wh of LiFePO4 battery storage, 2000W pure sine wave inverter, and features split phase bonding (for 220 volt) and a 6,000+ charge cycle. So you get 240v/4000W of transferable energy that can power heavy-duty washer/dryer or water heater with two units hooked together (\$6500).





This new solar battery pack is the only one now available with the ability to output 220 volts which is necessary to run a dryer and has the capacity of 10 Kilowatt/hours. That means a 2KW dryer and a 1KW washer could run for approximately three hours uninterrupted and, with 2400 watts of solar, can be recharged by sunlight (on a sunny day) in about 3.5 hours.

This eliminates the need for propane to heat the water and the electric grid or gas generator to power the washer/dryer.

Optional adjoining community room

An adjoining matching cabin includes another 1200 watt solar array and comes with a communications center that seats four and includes community WiFi.

BUDGET

The solar laundry:

- A-Frame cabin (pre-constructed) \$20K
- 8x10 ft trailer for A-frame (\$2500)
- 1200 Watts solar x 2 (\$5000)
- Bluetti ep500 Pro battery/generator X2 (\$8000)
- RV Washer/Dryer combination x 2 (\$2400)
- RV Tankless Water heater \$600
- Professional electrician and expenses (\$2500)
- Licenses and permits (\$1500)
- Construction costs (\$2500)
- Management of trailer for year (\$15K)
- Misc expenses (\$3K)

TOTAL \$63,000

The Comm Center:

- Bluetti ep500 battery/generator X2 (\$6000)
- Starlink satellite terminal (\$600 + yr service) \$2,000
- Community LTE using CBRS and WiFi (\$600)
- Four Chromebook laptops, printer, two 24" monitors (\$2000)
- Two E-bikes with trailer and charger (\$4000)
- A-Frame cabin (pre-constructed) \$20K
- 8x10 ft trailer for A-frame (\$2500)
- 1200 Watts solar x 2 (\$5000)
- Misc expenses (\$5000)

TOTAL \$34,000

TOTAL FOR BOTH SOLAR LAUNDRY AND COMM CENTER TRAILER: \$97,000

Misc Links

1. Kol Peterson is an ADU advocate with a background in environmental planning. Kol lives in an ADU that he completed in 2011 and teaches regular ADU classes for homeowners. He also owns Caravan- The The Tiny House Hotel with his wife. <https://accessorydwellings.org/>
2. Located in the Alberta Arts District, Caravan is a unique, one-of-a-kind hotel where travelers from around the world can experience what it's like to stay in a custom-made tiny house on wheels. <https://tinyhousehotel.com/>
3. Apply for an Accessory Dwelling Unit (ADU) permit. Get all forms for a complete ADU permit application and apply online. <https://www.portland.gov/bds/adu-permits>
4. Everything You Need to Know About Building an ADU in Portland, Oregon
<https://www.dwell.com/article/adu-building-guide-portland-oregon-5483109d>
5. Dave Spitzer started ADU PDX after the economic downturn of 2008. Over a decade in, ADU PDX has stuck to its principles of density and efficiency, designing over a hundred ADUs.
<https://adupdx.com/people/>
6. There are restrictions and requirements when adding an ADU to your property
<https://wolfind.com/tiny-homes/portland-or/>
7. Blokable container homes built in Vancouver include 20' and 40' size shipping containers.
<https://www.facebook.com/blokable>
<https://blokable.com/news/vertically-integrated-modular-housing-innovation/>
8. Online community based out of Portland, Oregon to support the greater community of tiny house lovers. <https://www.facebook.com/groups/tinyhouses/>
9. The Shelter to Housing Continuum
<https://www.oregonlive.com/news/2021/03/portland-city-council-residents-discuss-where-homeless-shelters-should-be-allowed-most-urge-wide-open-options.html>
10. St Johns Village and Hazelnut Grove on Interstate
<http://ahomeforeveryone.net/stjohnsvillage>
<https://www.facebook.com/HazelnutGrovePDX>
11. Map of Tiny Homes
<https://www.arcgis.com/apps/MapJournal/index.html?appid=ed5225ac3447494a9edc58d7ecb57e16>
12. Cascadia Clusters is a 501(c)(3) nonprofit developing opportunities for houseless individuals to gain valuable construction skills so they can build infrastructure that addresses service gaps in their own communities. <https://www.cascadiacusters.org>